

SHIRE

BUILT AROUND OUR REPUTATION

Garden Buildings

Pet Houses & Decking

SHIRE

BUILT AROUND OUR REPUTATION



Welcome to Shire Garden Buildings

Shire was established in 1945 – our factories now occupy some 20 acres they have been developed into modern well equipped efficient facilities that include a planing mill, self contained joinery production, undercover timber store and large warehouses that can hold some 10,000 buildings in stock.

Shire manufactures a wide choice of products, garden buildings, pine lodges, decorative pressure treated fence panels, pet houses and deck kits. The garden products contained in this brochure are sold through our established network of distributors who are able to offer the extra benefits and services as required of home delivery, assembly and product enhancement. Our distributors are able to advise you on any special design requirement you may have, whether this is a special size or height, a repositioning of a door(s) or window(s) or a totally bespoke building. You will also have the comfort of knowing that your building has been supplied by someone local who are there to continue to offer services as required. Some of our distributors have been with us for over 25 years!

Our distributors can also supply products from our other ranges for which brochures are freely available. If you encounter any problems then please contact us direct.



We hope you enjoy perusing through this brochure and that you find the building you require if not then please discuss your needs with our distributor. Most buildings are shown in our brochures decorated with flowers, tools, seats, toys etc these are shown for photographic purposes only and are not included in the sale of the building

Simon Smeeth

MANAGING DIRECTOR



Shire PEFC Chain of Custody number
BMT - PEFC - 0097



Shire FSC Chain of Custody number
037 / TT - CoC - 1951

**Call us on +44 (0) 1945 465295
or email sales@shiregb.co.uk**

Brigstock Road, Wisbech, Cambridgeshire PE13 3JJ
Fax: +44 (0) 1945 582673 • www.shiregb.co.uk

Contents

All dimensions given in metric are correct – imperial dimensions are for guidance only.

The designs, layouts & wording contained in this brochure are protected by copyright and registered designs any attempt to copy or reproduce these buildings or content of this brochure will result in prosecution

MULTI-FUNCTIONAL GARDEN SHEDS 4	SUMMERHOUSES 17	Bird Table 29
Wroxham 5	Elton 18	Bird House 29
Suffolk 5	Arreton 18	Avairy Coop 29
Iceni 5	Milton 19	Small Pet House 29
Security Apex 6	Winton 19	Hutch and Drop Run 30
Atlas 6		Mansion Hutch 30
Bison Workshop 7	LITTLE HOUSES 20	Poultry Coop 30
Mammoth 7	Bunker 21	Animal Ark 30
Norfolk 8	Cottage 21	Hen House 30
Murrow Cornershed 8	Club 22	Pet Run 30
	Hobby 22	
STORAGE SHEDS 9	Salcey 23	STORAGE 31
Caldey 10	Stork 23	Wheelie Bin Store 31
Lewis 10	Loft 24	Storage Box 31
Orkney 11	Hide 24	Handy Store 32
Rothesay 11	Bunny 24	Jura Store 32
	Lodge 25	Bike Store 32
ROOMS FOR THE GARDEN 12	Crib 25	Garden Stores 32
Windsor 13	Jailhouse 26	Useful Store 33
Sandringham 13	Den 26	Giant Store 33
Goodwood 14		
Woburn 14	PET HOUSES 27	DECK KITS 34
Blenheim 15	Country Hutch 27	Type 1 34
Security Cabin 15	Apex Dog Run 28	Type 2 34
Beaulieu 16	Sanda Run 28	Type 3 34
Fleur de Lys 16	Sark Kennels 29	Type 4 34
	Pent Kennels 29	PINE LODGES 35



Quality Without Compromise

Shire buildings are produced to the highest standards using quality timbers from sustainable sources. Timber sizes detailed are the actual sizes after the timber has been planed and profiled.

Normally the walls of all buildings will be manufactured using Pine tongue and groove (T&G) Shiplap pattern boarding 12 x 120mm.

T&G Pine Log pattern 19 x 93mm is another option you may wish to consider.

In all choices of wall timber Pine framework will be used (which varies in thickness dependant upon building 'range'). Pine T&G boarding 12 x 120mm is used to produce roofs and floors unless otherwise stated.

All Details Considered

We are proud of our buildings and have endeavoured to consider all details in their design using quality fixtures and fittings – all exterior fittings are treated against rust and felt is green mineral with a 10 metre roll weighing 20 kilos. Facia, finishing timbers, assembly instructions, hardware and glass are supplied to enable assembly of the building.

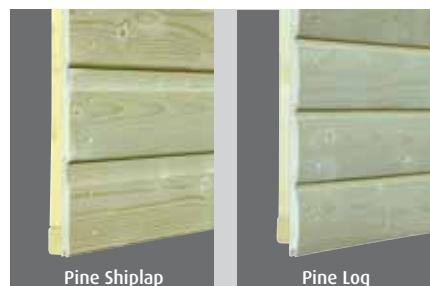

Shire buildings are pre treated (unless otherwise specified) using a high quality anti-fungicide wood protection primer, our buildings are also available pressure – treated, which is the best long-term protection available.

Feedback Welcomed

As Shire are a progressive company customer feedback is welcomed. Shire reserve the right to modify design and/or specification. All sizes stated are approximate – the metric measurements stated refer to the floor size.

When choosing a location for a building allowance should be made for roof overhangs. It is essential that all our buildings are assembled onto a firm, level base. Assembly onto an uneven base will cause problems.

We hope you enjoy looking through our brochure and trust that you are able to find a building to suit your purpose. If not, remember that buildings can be altered as you wish – windows added or taken away, make double doors, add a stable door, hinge the roof (yes, we were asked, and did, this) – you name it, we can do it. If you have any queries please telephone or visit your local distributor whose details can be found on the back of this brochure.

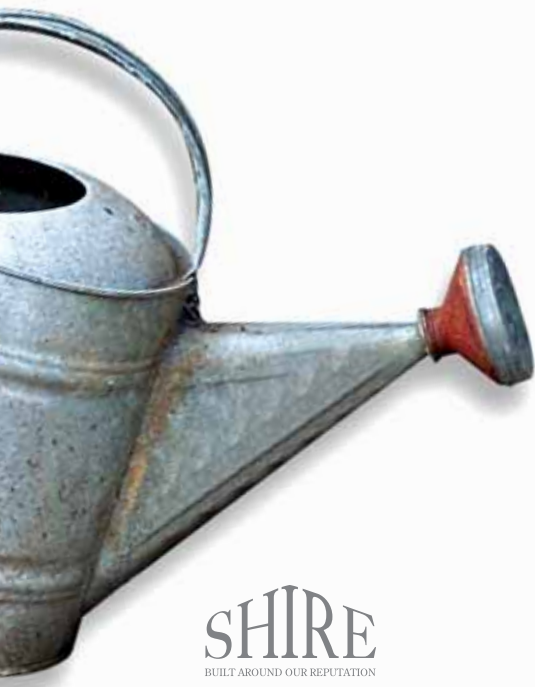

SHIRE
BUILT AROUND OUR REPUTATION

Wroxham PAGE 5

Appealing transverse apex

Suffolk PAGE 5

Decorative garden shed

Iceni PAGE 5

Shed/Greenhouse combo

Security Apex PAGE 6

Store with confidence

Atlas PAGE 6

General utility building

Bison Workshop PAGE 7

Purpose built workshop

Mammoth PAGE 7

Stylish workshop

Norfolk PAGE 8

Versatile workshop

Murrow

Cornershed PAGE 8

Building for a corner location

Multi-functional Garden Sheds

Designed to Work

A range of attractive, functional buildings for the serious (or trainee) DIY'er, gardening enthusiast or contemplator!

A comfortable space to work in with a minimum INTERNAL eaves height of 1790mm (6') - ridge heights will vary dependant upon the width of building but are a minimum internally of approximately 2110 mm (7'). Robustly constructed using sturdy wall framework measuring 45 x 45mm (2 x 2") or 70 x 45mm (3 x 2") see Bison and Mammoth, spaced at not more than 800mm (2' 8").

All windows are properly morticed and tenoned profiled and weather resistant, most are opening. The window has a unique profiled 'lip' which covers the

aperture of the opening in the panel making it weather resistant. Casement stays have 2 levels of opening and are supplied fitted. 3mm horticultural glass is retained by profiled beading which is pre-mitred (no awkward corners to be cut).

Unless otherwise specified doors are 1780mm (5' 10") high and 905mm (5' 11½") wide. Piano hinges are fitted on the right as standard (left hand hung can be specified) and supplied with a two way operational lock.

Optional extras for all of the 'Blue' range are:

Strengthened floor produced using 16 x 120mm boarding on 45 x 45mm (2 x 2") joists.

Shelving made from Pine boarding 19 x 95mm and 250mm (10") wide, supplied with all necessary fixings.

Workbench is made from Pine boarding 12 x 120mm and is 475mm (18¾") wide. Complete with all fixings necessary.

IMPORTANT: As a security measure all doors are robustly constructed and fitted with concealed full length piano hinges. All doors are hinged on the right unless otherwise ordered.



Wroxham

An attractive variation on the usual garden shed, one criss-cross opening window is supplied as standard – further windows may be purchased if required. The photograph shows 2390 x 1790mm (8' x 6') style C with an extra window. Don't forget, shelves and workbenches are also available. Insert shows Suffolk which has all the features and available options as the Wroxham.

SIZES

2390 x 1790mm (8' x 6')

2990 x 1790mm (10' x 6')

2990 x 2390mm (10' x 8')

The first dimension shown refers to the side with the door.

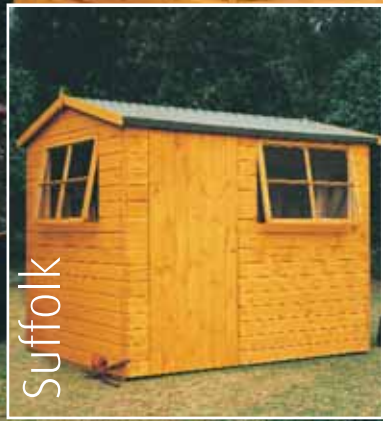

Suffolk



Iceni

The Iceni is part greenhouse, part shed for a variety of uses – a truly multi-functional building. For safety reasons the large front window does not open and is supplied with plastic glazing, the opening side window is supplied with glass. The photograph shows 2390 x 2390 (8x8) style B with left hand hung door. Workbench is available as an optional extra, as is the stable door.

SIZES

2390 x 1790mm (8' x 6')

2390 x 2390mm (8' x 8')

The photograph shows 2390 x 2390mm (8' x 8') style with left hand hung door. Also shown with optional workbench and stable door.

The first dimension shown refers to the side with the door.

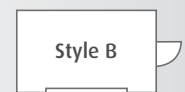
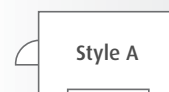

Security Apex

Take extra care of those valuable tools by choosing this building designed to aid security. The high level fixed windows allow daylight in whilst not permitting intruders. The door is strongly constructed with a full-length hidden hinge and a good quality lock. Photograph shows 2390 x 1790 mm (8' x 6') pressure treated.

SIZES

2390 x 1790mm (8' x 6')

2690 x 1790mm (9' x 6')

2990 x 1790mm (10' x 6')

2990 x 2390mm (10' x 8')

2990 x 2990mm (10' x 10')

The 2nd dimension shown refers to the side with the door.



Atlas

Where to put the lawn mower and do some DIY? The Atlas must be your answer, big enough for the ride on lawn mower and still space available for the larger projects to be undertaken. The photograph shows 2990 x 1790mm (10' x 6') style A with double door option. An optional shelf would save on precious floor space and allow your tools to be immediately to hand.

SIZES

2690 x 1790mm (9' x 6')

2990 x 1790mm (10' x 6')

2990 x 2390mm (10' x 8')

2990 x 2990mm (10' x 10')

The 2nd dimension shown refers to the side with the door.



Bison Workshop



Large and larger. Manufactured using 70 x 45mm (3 x 2") framework and with a 16mm (3/4") floor on 70 x 45mm (3 x 2") joists the Bison Workshop is ideal for all manner of working equipment or just for people who like (or need) lots of space to work in. The large fully opening windows make it the perfect working environment and the double doors – 1346mm wide (4' 5") – allow easy access. The photograph shows 3580 x 2990mm (12' x 10') style A with an optional workbench.

SIZES



Style A

2990 x 2390mm (10' x 8')
3580 x 2390mm (12' x 8')
4180 x 2390mm (14' x 8')



Style B

2990 x 2990mm (10' x 10')
3580 x 2990mm (12' x 10')
4180 x 2990mm (14' x 10')

The first dimension shown refers to the side with the door.

4790 x 2390mm (16' x 8')
4790 x 2990mm (16' x 10')
5990 x 2990mm (20' x 10')



Mammoth

A light and airy, stylish workshop. Manufactured using 70 x 45mm (3 x 2") framework. Also has 16mm (3/4") floor on 70 x 45mm (3 x 2") joists. Supplied as standard with 2 large windows that open fully. The double doors measure 1805mm (5'11") high and 1420 mm (4'8") wide. Loads of space, lots of light – ideal working conditions. Photograph shows 10 x 18 Mammoth with 2 optional windows and optional shelves.

SIZES

3730 x 3590mm (12' x 12')
3730 x 5385mm (12' x 18')
3730 x 7180mm (12' x 24')
3730 x 8975mm (12' x 30')
3156 x 3016mm (10' x 10')
3156 x 4524mm (10' x 15')
3156 x 6032mm (10' x 20')
3156 x 7540mm (10' x 25')

The door panel/ both windows panels/ plain panels are interchangeable - they can be placed either side or each gable end to suit any individual requirement. (10' sizing is supplied in 5' section, 12' sizing is supplied in 6' sections)

Norfolk

Opening windows along the front panel make the interior bright and airy and at 1790mm (6') at the front the building is high enough for all but the tallest people to work in comfort – and for the tallest people the roof may be reversed (at no extra cost) putting the 'lower' 1790mm (6') side at the back and 2110+mm (7'+) at the front. The photograph shows 2690 x 1790mm (9' x 6') style B. An optional workbench would be the ideal finishing touch.

SIZES

- 2390 x 1790mm (8' x 6')
- 2690 x 1790mm (9' x 6')
- 2990 x 1790mm (10' x 6')
- 2990 x 2390mm (10' x 8')
- 2990 x 2990mm (10' x 10')

The first dimension shown refers to the side with the door.

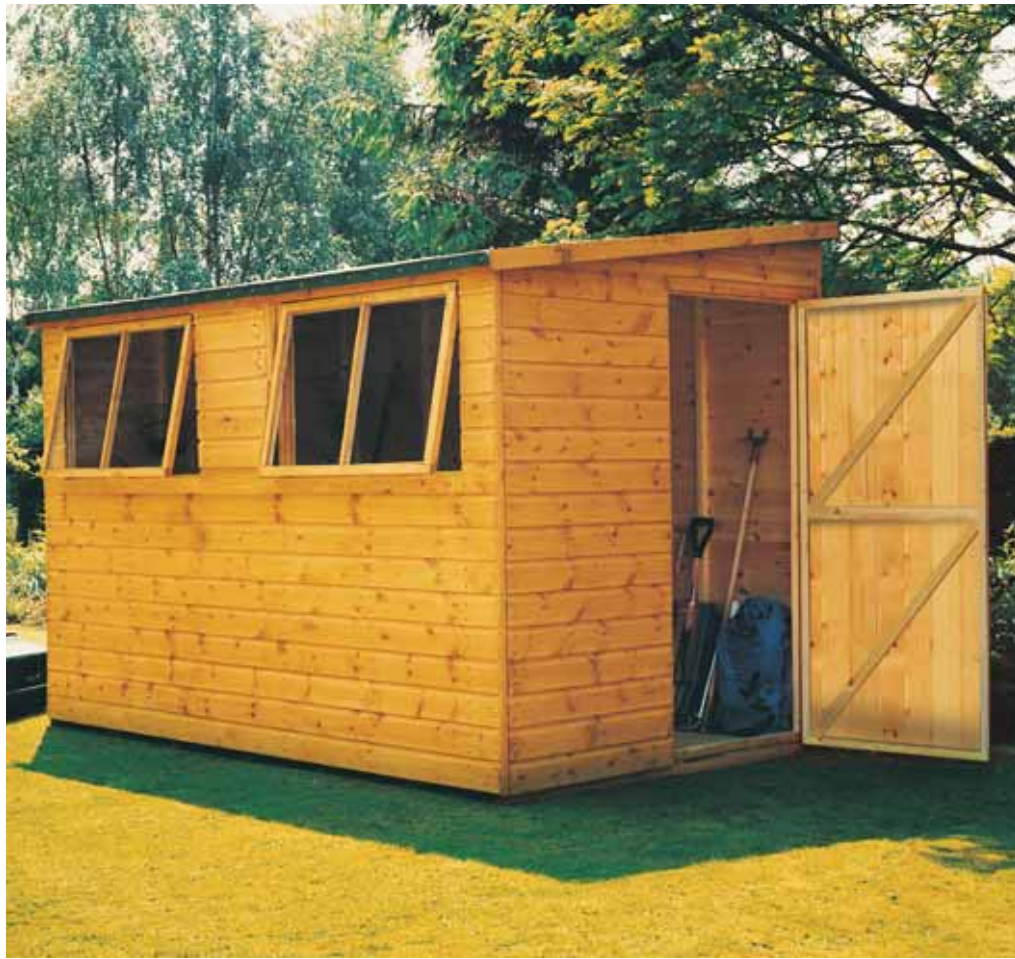

Murrow Cornershed

The Murrow Cornershed fits nicely into any size of garden allowing ample work and/or storage space whilst making the best use of a corner. The photograph shows 2005 x 2005mm (7' x 7') with optional shelving.

SIZES

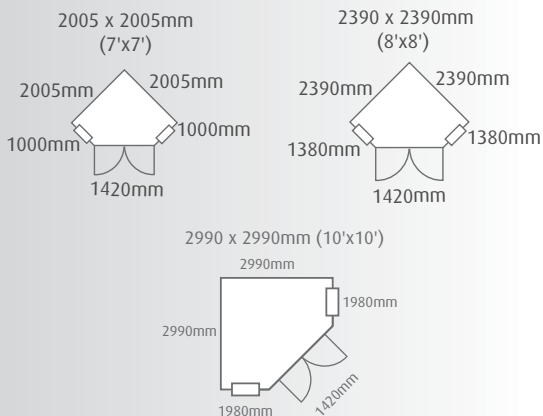

Caldey PAGE 10

Complete versatility

Lewis PAGE 10

Storage no problem

Orkney PAGE 11

Verandah an option

Rothesay PAGE 11

Shed or summerhouse?



Storage Sheds

Ideal for Storage

Ranges of buildings that look attractive and yet when in use will create more space in your house, garage or loft. Ample storage space is provided with a minimum external eaves height of 1775mm (5' 9") – ridge heights will vary dependant upon the width of building but are a minimum internally of 1833mm (6' 0").

Strongly constructed using 35 x 35mm (1¼" x 1¼") wall framework spaced not more than 800mm (2' 8") apart.

Unless otherwise specified doors are 1695 mm (5' 6 ½") high and 762mm (2' 6") wide. Piano hinges are fitted on the right as standard (left hand hung can be specified)

and supplied with a two way operational lock. Joinery made morticed & tenoned windows are profiled for weather resistance. The 3mm glass is retained using profiled beading, which is premitred.

IMPORTANT: As a security measure all doors are robustly constructed and fitted with concealed full length piano hinges. All doors are hinged on the right unless otherwise ordered.



Caldey

Complete versatility is catered for by the choice of door and window layout provided in the styles available. By design additional headroom is afforded adjacent to the windows. All windows are fixed. The photograph shows 2390 x 1790mm (8' x 6') style A.

SIZES

- 1790 x 1190mm (6' x 4')
- A + B + C + D: 1 pane window
- 2090 x 1490 mm (7' x 5')
- A + B: 2 pane window
- C + D: 1 pane window
- 2390 x 1790mm (8' x 6')
- A + B: 3 pane window
- C + D: 2 pane window
- 2990 x 1790mm (10' x 6')
- A + B: 2 x 2 pane window
- C + D: 2 pane window
- 2990 x 2390mm (10' x 8')
- A + B: 2 x 2 pane window
- C + D: 2 pane window
- 3590 x 2390mm (12' x 8')
- A + B: 2 x 2 pane window
- C + D: 2 pane window

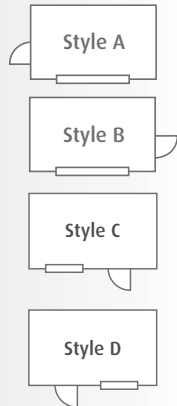

The first dimension shown refers to the side with the window or window and door.



Lewis

An extra room in the garden to store all those household items that clutter your kitchen or under the stairs – or for the lawnmower and garden tools – or even both. As large or as small as you need. All windows are fixed. The photograph shows 2390 x 1790mm (8' x 6') style B.



SIZES

- 1790 x 1190mm (6' x 4')
- 1 pane window
- 2090 x 1490mm (7' x 5')
- 2 pane windows
- 2390 x 1790mm (8' x 6')
- 3 pane windows
- 2990 x 1790mm (10' x 6')
- 2 x 2 pane windows
- 2990 x 2390mm (10' x 8')
- 2 x 2 pane windows
- 3590 x 2390mm (12' x 8')
- A + B: 2 x 2 pane windows

The first dimension shown refers to the side with the window.

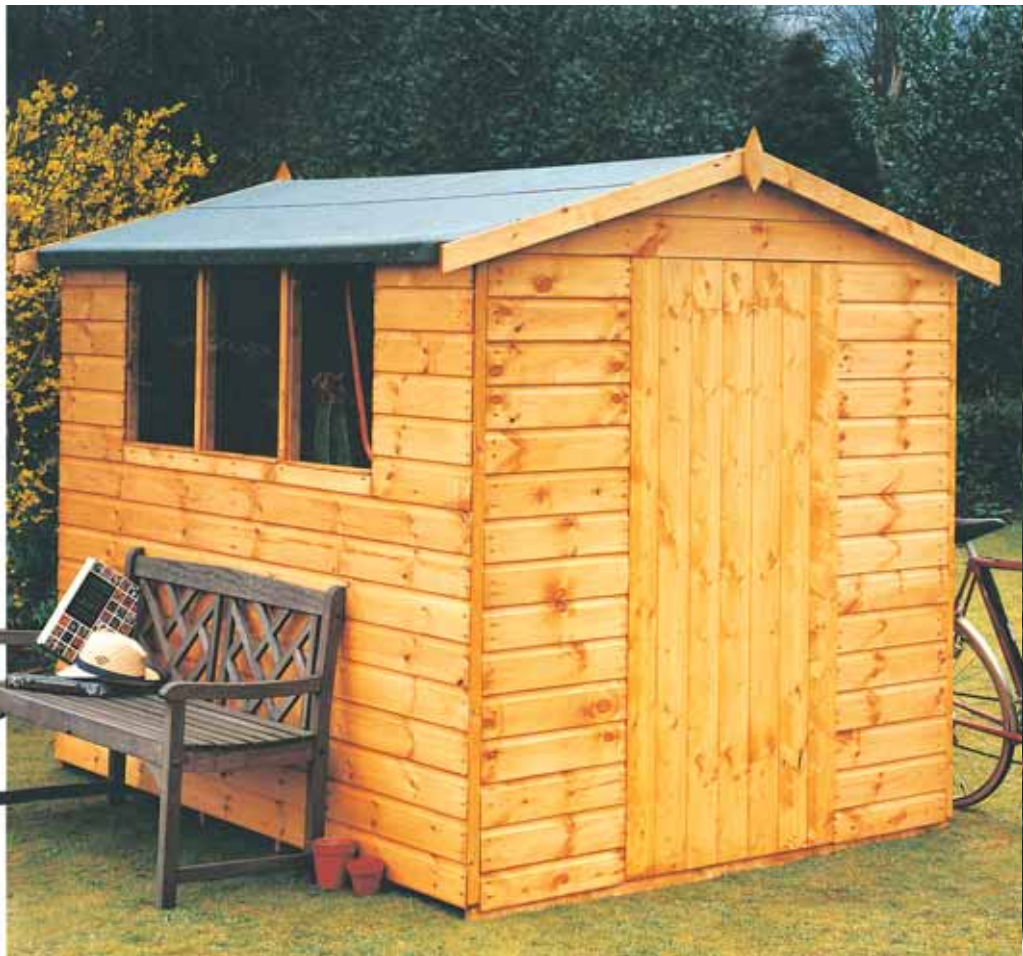

Orkney

Every bit as useful as a 'normal' door in the end garden building – just more attractive – the roof overhang without the optional verandah is 160mm (6"). Four fixed windows are fitted as standard. The side panels are interchangeable – the side windows will then be at the back of the building which may suit your purpose better. The photograph shows 2390 x 1790mm (8'x6') without verandah (see Rothesay for photo of verandah).

SIZES

2090 x 1490mm (7' x 5')

2390 x 1790mm (8' x 6')

2990 x 1790mm (10' x 6')

With optional 900mm (3') verandah
(see Rothesay)

2090 x 2390mm (7' x 8')

2390 x 2690mm (8' x 9')

2990 x 2690mm (10' x 9')

The first dimension shown refers to the side with the door.



Rothesay

Summerhouse or shed – distinctly decorative whilst retaining all the functionality required of a garden building. Three decorative, opening windows are fitted as standard and an additional side window is available as an option. The side panel with window may be positioned at either side. The photograph shows 1980 x 1790mm (7' x 6') with optional verandah. Roof overhang without verandah is 160mm (6") – as Orkney.

SIZES

1980 x 1490mm (7' x 5')

1980 x 1790mm (7' x 6')

2990 x 1790mm (10' x 6')

With optional 900mm (3') verandah

1980 x 2390mm (7' x 8')

1980 x 2690mm (7' x 9')

2990 x 2690mm (10' x 9')

The first dimension shown refers to the side with the door.



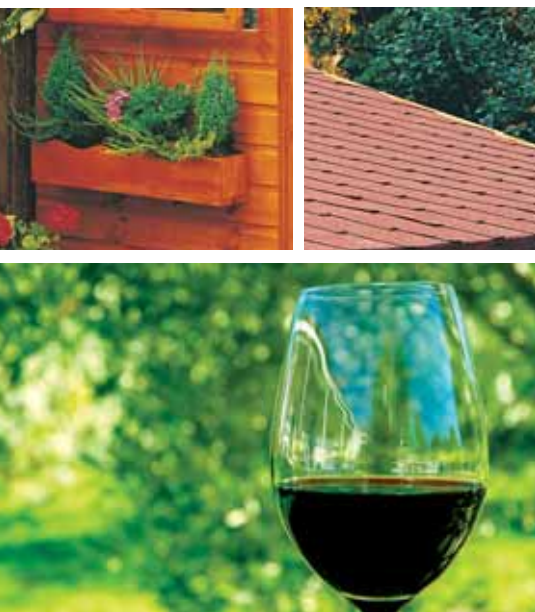

Windsor PAGE 13

Fantastic finish to any corner

Sandringham PAGE 13

Georgian glazed beauty

Goodwood PAGE 14

The perfect retreat

Woburn PAGE 14

Delightful with verandah

Blenheim PAGE 15

Contemporary style

Security Cabin PAGE 15

With security features

Beaulieu PAGE 16

A superior garden room

Fleur De Lys PAGE 16

Features unique bay window

SHIRE
BUILT AROUND OUR REPUTATION

Rooms for the Garden

Beautiful and Useful

With an internal eaves height of 1790mm (6') and a ridge height of 2110mm (7') and over our 'Gold' range of Garden Rooms are suitable for almost anything – an extra room for overnight guests, an ideal place to serve drinks during your barbeque, to have sight but not sound of the children – or vice versa, or just simply to relax in and enjoy your garden.

Constructed using the best quality solid Pine with wall framework measuring 45 x 45mm (2 x 2"), spaced at not more than 800mm (2' 8").

All windows are properly morticed and tenoned, they are opening, profiled and weather resistant. The window has a unique profiled 'lip' that covers the aperture of the opening in the panel making it weather resistant.

Brass casement stays have 2 levels of opening and are supplied fitted. 3mm horticultural glass is retained by profiled beading that is pre-mitred (no awkward corners to be cut).

Doors are morticed and tenoned, profiled and weather resistant – they match the windows, with weather resistant lip and mitred beading.

Doors are 1732mm (5' 8¼") high – double doors have a total width of 1350mm (4' 5¼") – the 'lip' covers the aperture. Brass handles add the finishing touch.

Facia that has been shaped into gentle curves and completes the look of sophisticated charm. No detail has been overlooked – the finial is even shaped! If you choose a building with a verandah the balustrade will be shaped.

We pride ourselves on our attention to detail – doors, windows, beading, facia, finials and if applicable balustrade railings and window boxes are all designed to fully co-ordinate with each other adding 'star quality' to beautifully designed buildings.

Optional extras for all of the 'Gold' range are:

Window boxes. Shaped to co-ordinate with the shaped facia.

Toughened glass. 4mm toughened to comply with BS6206 instead of 3mm horticultural.

Felt tiles give a tiled effect and are available in red (pictured above), green or black.



Windsor

Ingeniously shaped to be primarily but not exclusively sited in a corner location providing an inspirational feature. The Georgian style double doors and opening windows ensure ample light and ventilation whilst allowing a remarkably wide viewing angle from which to appreciate your garden. The photograph shows 2390 x 2390mm (8' x 8') with optional window boxes. Not supplied with profiled fascia.

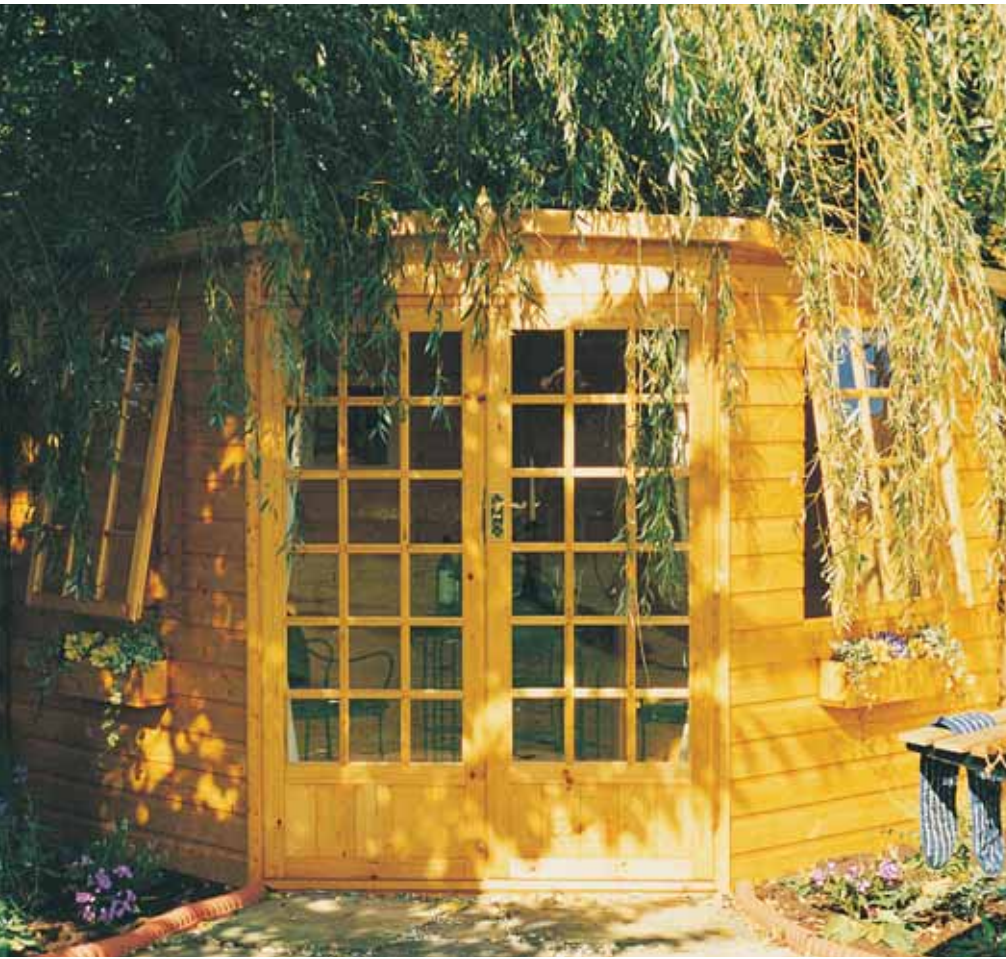

SIZES

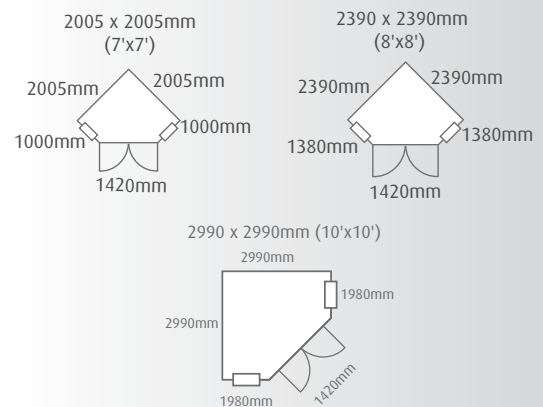

Sandringham

Double doors co-ordinate with our unique bay window to give the Sandringham character and quality. Matching opening side windows, as seen on the Windsor, are available as an option. The photograph shows 2990 x 2390mm (10' x 8') style C with two optional opening side windows.

SIZES

2990 x 1790mm (10' x 6')

2990 x 2390mm (10' x 8')

The first dimension refers to the side with the door.

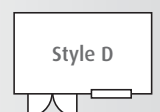

Goodwood

Our unique non-opening profiled bay window adds distinction to a classic design. Matching opening side windows, as seen on the Beaulieu, are available as an option. The photograph shows 2990 x 2390mm (10' x 8') with optional opening side windows.

SIZES

2690 x 1790mm (9' x 6')
 2990 x 1790mm (10' x 6')
 2990 x 2390mm (10' x 8')
 2990 x 2990mm (10' x 10')

The first dimension refers to the side with the door.

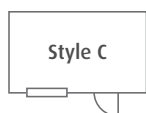

Woburn

The many large windows allow panoramic views of your garden from which to enjoy the warmth of a summer-day, delightful with or without the optional verandah. The roof overhang is 300mm (1') without verandah. Two opening side windows as pictured are supplied as standard. The front windows do not open. The photograph shows 2690 x 1790mm with optional 900mm verandah (9' x 6' + 3' verandah).

SIZES

2690 x 1790mm (9' x 6')
 2690 x 2390mm (9' x 8')
 2990 x 2390mm (10' x 8')

With optional 900mm (3') verandah:
 2690 x 2690mm (9' x 9')
 2690 x 3290mm (9' x 11')
 2990 x 3290mm (10' x 11')

The first dimension refers to the side with the door.
 Not available with front panel 2390mm (8').

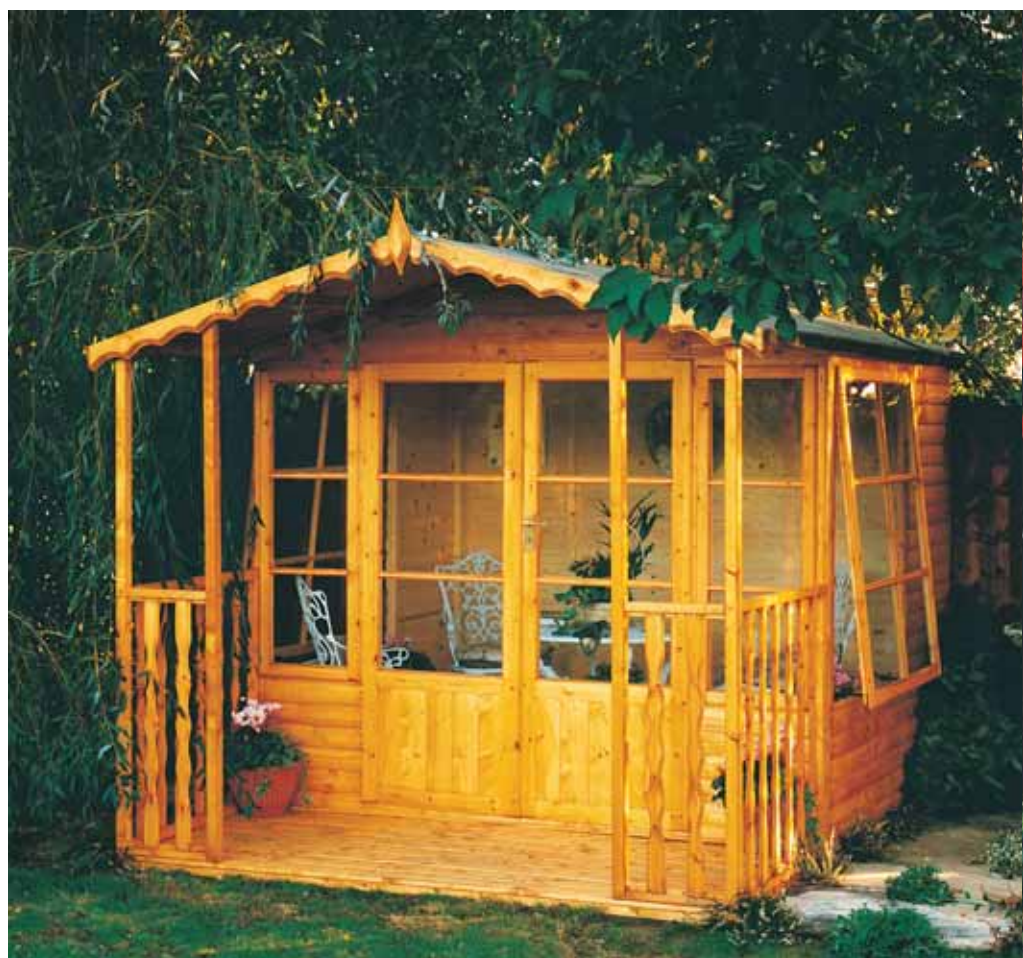

Blenheim

Clever bi fold doors allow this contemporary Summerhouse to be opened along the 2990mm (10') side. The two opening side windows are supplied as standard.

The Summerhouse is pictured with optional felt tiles. Photograph shows 2990 x 1790mm (10' x 6')

SIZE

2990 x 1790mm (10' x 6')

2990 x 2390mm (10' x 8')

The first dimension refers to the side with the door.



Security Cabin

It is possible to have an attractive and secure building. For security the door is fitted with a piano hinge and shutters function. The window opens inwards. The door and shutters are supplied with decorative olde world style false hinges. The side windows and window boxes are optional extras. The photograph shows 2990 x 2390mm (10' x 8') with optional window box.

SIZES

2690 x 1790mm (9' x 6')

3990 x 1790mm (10' x 6')

2990 x 2390mm (10' x 8')

2990 x 2990mm (10' x 10')

The first dimension shown refers to the side with the door.



Style C

Style D

Beaulieu

An attractive well designed building – an idyllic garden-room.

Two windows on each side and two on the front (six in total)

provide a light, airy building.

The Beaulieu can be insulated

and/or lined with solid pine

boarding and even sub-divided to

form more than one room. The

photograph shows 3580 x 3580mm

(12' x 12')

produced in Log pattern

cladding with optional window boxes.



SIZES

2990 x 2390mm (10' x 8')

2990 x 2990mm (10' x 10')

2990 x 3580mm (10' x 12')

3580 x 3580mm (12' x 12')

The first dimension refers to the side with the door.

Fleur De Lys

A charming building that will add a touch of panache to your garden,

its graceful proportions enhanced by

enchancing Georgian lattices conspire

together to ensure that the building

will be the centre-piece of your garden

design. An extra side window is

available as an optional extra. The

photograph shows 2390 x 2090mm

(8' x 7') + optional verandah 900mm

(3'), with optional extra side window.

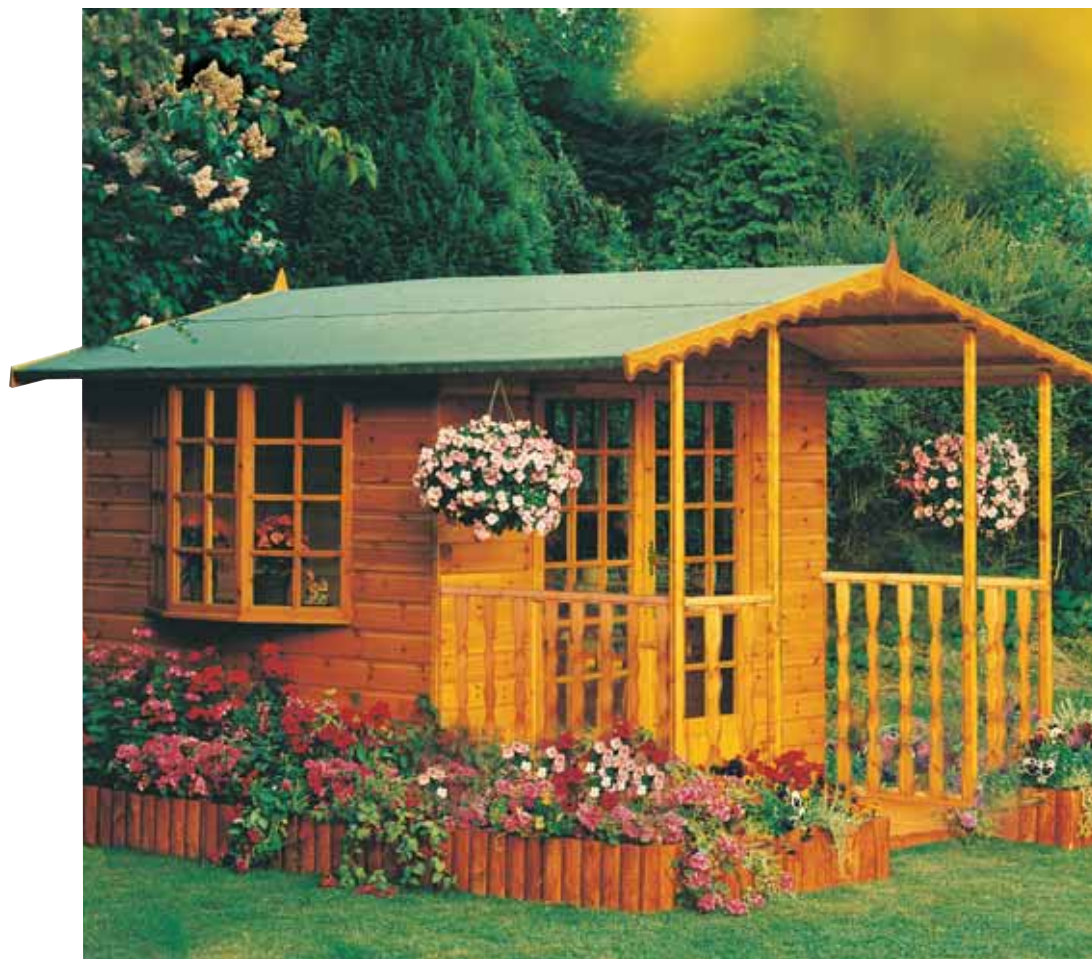

SIZES

2390 x 1790mm (8' x 6')

2390 x 2090mm (8' x 7')

2390 x 2390mm (8' x 8')

With optional 900mm (3') verandah:

The first dimension refers to the side with the door.

Elton PAGE 18

Three-quarter length windows

Arreton PAGE 18

Eight sides – unusual shape

Milton PAGE 19

Allows comprehensive views

Winton PAGE 19

A shady summerhouse



SHIRE
BUILT AROUND OUR REPUTATION

Summerhouses

Relax and Enjoy

After all the hard work sit back and appreciate the beauty of your garden, or sit and enjoy a good book in peace and tranquillity. The eaves are 1715mm (5' 7½") internally with a minimum height of 1833mm (6' ½") at the ridge (ridge heights will vary dependant upon the width of the building).

Walls are constructed using 35 x 35mm (1¼" x 1¼") spaced at no more than 800mm (2' 8") intervals.

Fixed attractive framed windows are properly morticed and tenoned – they are profiled and weather resistant with our unique profiled 'lip'. Pre-mitred and profiled beading holds 3mm horticultural glass in position.

Doors are 1616mm (5'3¼") high and double doors have a width of 1360mm (4'5½") , single doors are 676 mm (2'2¾") wide, morticed and tenoned, profiled and weather resistant – they co-ordinate with the windows, again with mitred beading and profiled 'lip'.



Elton

Savour the privacy of your garden with this well defined summerhouse. Large three quarter glazed double criss-cross windows are fixed – the matching single door creates a light and stylish chalet. The roof overhang is 300mm (1'). The photograph shows 1980mm x 1790mm (7' x 6').

SIZE

- 1980 x 1490mm (7' x 5')
 - 1980 x 1790mm (7' x 6')
 - 2990 x 1790mm (10' x 6')
- The first dimension refers to the side with the door.



Arreton

A truly unique and beautiful centre point for any garden. A private office, or just a place to sit quietly and contemplate? Windows in the side walls, as shown in the photograph, fixed or opening, are available as optional extras. Window boxes as pictured may also be purchased as required. The roof is produced using orientated strand board.

SIZE

- 2390 x 2390mm (8' x 8')

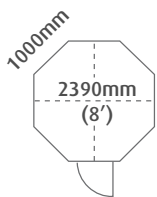

Milton

Enjoy comprehensive views of your garden from this appealing summerhouse with its roof overhang of 300mm (1') and large glazed front doors with matching fixed side lights ensuring a perception of space and comfort. One fixed side window is fitted as standard but can be made to open as an option. The photograph shows 2390 x 1790mm (8' x 6') with optional verandah and opening side window.

SIZES

2390 x 1790mm (8' x 6')
2390 x 2390mm (8' x 8')

With optional 900mm (3') verandah:
2390 x 2690mm (8' x 9')
2390 x 3290mm (8' x 11')

The first dimension refers to the side with the door.



Winton

The correlation between the double doors and side window gives distinction, the optional shady canopy adds a certain style. The roof overhang without the canopy is 300mm (1'). A further side window is an optional extra. The photograph shows 2390 x 1790mm with 900mm (8' x 6' + 3') canopy.

SIZES

2390 x 1790mm (8' x 6')
2390 x 2390mm (8' x 8')

With optional 900mm (3') canopy:
2390 x 2690mm (8' x 9')
2390 x 3290mm (8' x 11')

The first dimension refers to the side with the door.

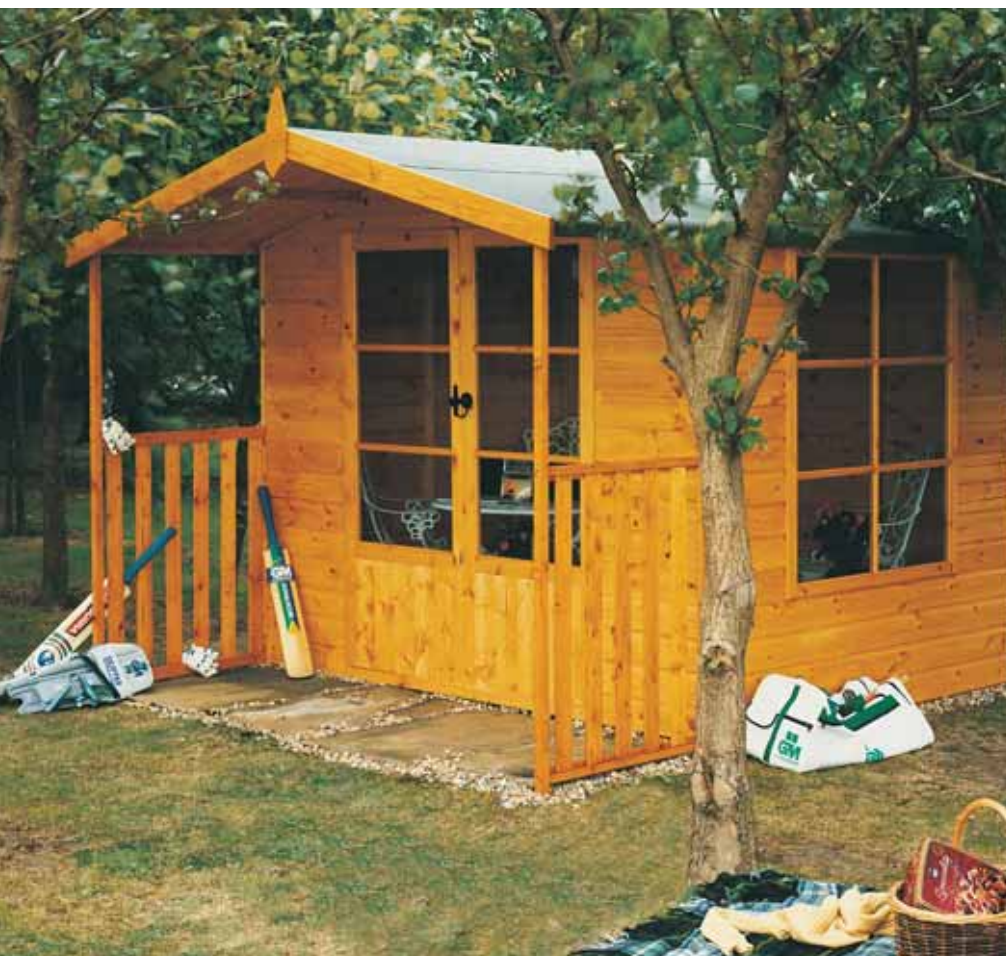

Bunker PAGE 21

A getaway from parents

Cottage PAGE 21

Delightful dormer window

Club PAGE 22

Cute and shady

Hobby PAGE 22

Charming with canopy

Salcey PAGE 23

Strength in design

Stork PAGE 23

A space to call their own

Loft PAGE 24

Complete with upstairs

Hide PAGE 24

Suits a small garden

Bunny PAGE 24

Pretty and petite

Lodge PAGE 25

A place for a sleepover?

Crib PAGE 25

A versatile playhouse

Jailhouse PAGE 26

For cowboys and indians?

Den PAGE 26

Premier playhouse

SHIRE
BUILT AROUND OUR REPUTATION

Little Houses

For Little People

How to keep children occupied during the school holidays? An age old problem that can be helped by the gift of their own little house. Years of pleasure will result for both user and spectator.

Eaves and ridge heights vary from little house to little house, some windows open and some are fixed – individual specification is given against each building. The attractively framed windows are properly morticed and tenoned – they are profiled and weather resistant with our unique profiled 'lip'.

SAFETY FIRST

As a safety precaution all windows are provided with plastic glazing material which is held in place by pre-mitred and profiled beading.

Walls are constructed using 35 x 35mm (1¼ x 1¼") spaced at no more than 800mm (2'8") intervals.

The roofs of the Club, Bunker and Hide are produced using Oriented Strand Board.

Some little houses are supplied with shaped fascia, window boxes and verandah railings – all co-ordinated with the attention to detail found on the windows to give a stunning effect.

Shaped fascia, window boxes and railings are available as optional extras if not included as standard with the building.

Felt tiles are available as an option in red or green – as shown on The Cottage and The Loft.

Our photographs show what may be achieved with the application of coloured preservative. Buildings are supplied pre-treated in a honey brown colour that can be over painted and coloured as you wish.

IMPORTANT: All Little Houses comply with BS5665 EN71.



Bunker

'Water gun ports' and observation points are for the commander and his troops whilst the 'enemy' (all parents) either try to attack or retreat to a quiet house. Upside down shaped fascia along the front edge softens the lines and completes every little boy's (or girl's) dream. The door is 795mm (2' 7½") high.



SIZE

1790 x 1190mm (6' x 4')

Internal eaves height:
910mm (3')

Internal ridge height:
1610mm (5'3½")

The first dimension refers to the side with the door.

Cottage

A 'Hansel and Gretel' dream cottage in your own garden. Five windows – including one opening side window and a delightful dormer window – add a fairy tale charm. Shaped fascia and two window boxes add the finishing touches.

The 'upstairs' is as detailed in The Loft and further window boxes are available as required. The photograph shows the option of felt tiles.



SIZE

1790 x 2390mm (6' x 8')

Internal eaves height:
1365mm (4'6") + 172mm (6')

Internal ridge height:
2360mm (7'10")

The first dimension refers to the side with the door.

Club

A delightful building finished with a cute and shady canopy. The large non-opening criss-cross window gives a light and airy interior. The shaped fascia as shown in the photograph is available as an optional extra.

SIZE

1490 x 1190 mm (5' x 4') plus 300mm (1') canopy.

Internal eaves height: 1240mm (4'1")

Internal ridge height: 1515mm (5')

The first dimension refers to the side with the door.



Hobby

A charming building which will give continued pleasure for many years. Front windows are fixed, fascia and canopy railings are not shaped as standard.

SIZE

1790 x 1190mm (6' x 4') plus 595mm (2') canopy.

Internal eaves height: 1240mm (4'1")

Internal ridge height: 1570mm (5'2")

The first dimension refers to the side with the door.

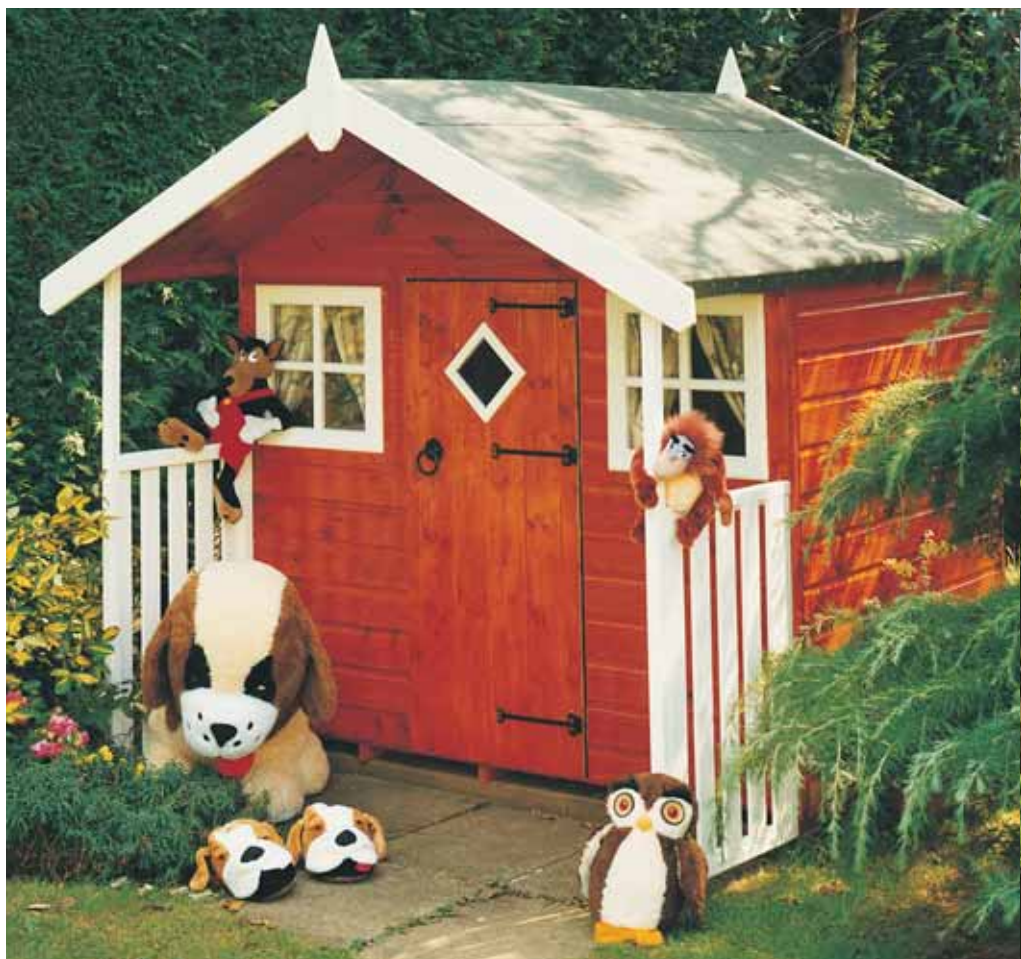

Salcey

This playhouse is one of the highest specification playhouses available with 28mm thick interlocking logs to the four sides. We have managed to combine tremendous strength in construction whilst maintaining an exquisite design.

SIZE

1790 x 2090mm including verandah (6' x 7')
 External eaves height: 1251mm (4' 1")
 External ridge height: 1541mm (5' ½")

The first dimension refers to the side with the door.



Stork

We all wish for a space to call 'my own'!
 The picture shows the optional platform which adds an extra 1000mm (3') in height.

The ladder maybe positioned to the side as pictured or at the front.

SIZE

1790 x 1190 + 600mm canopy
 (6' x 4' x 2')

Internal eaves height:
 1154mm (3'9½")

Internal ridge height:
 1566mm (5'1½")

The first dimension refers to the side with the door.



Loft

Step into a world of make-belief.

A beautiful building that because of its stunning appearance will give pleasure to all who see it. The side window opens, all other lower windows may open as an option. Artificial shutters and profiled fascia complete the picture.

Two shaped window boxes are supplied as standard and others may be purchased as required. The 'upstairs' is 830 x 1720mm (2'9" x 6') and comes complete with balustrade, ladder and banister rail. The photograph shows optional felt tiles and window boxes.

SIZE

2390 x 1790mm (8' x 6')

Internal eaves height:
1365mm (4'6") + 1720mm (6')

Internal ridge height: 2360mm (7'10")

The first dimension refers to the side with the door.

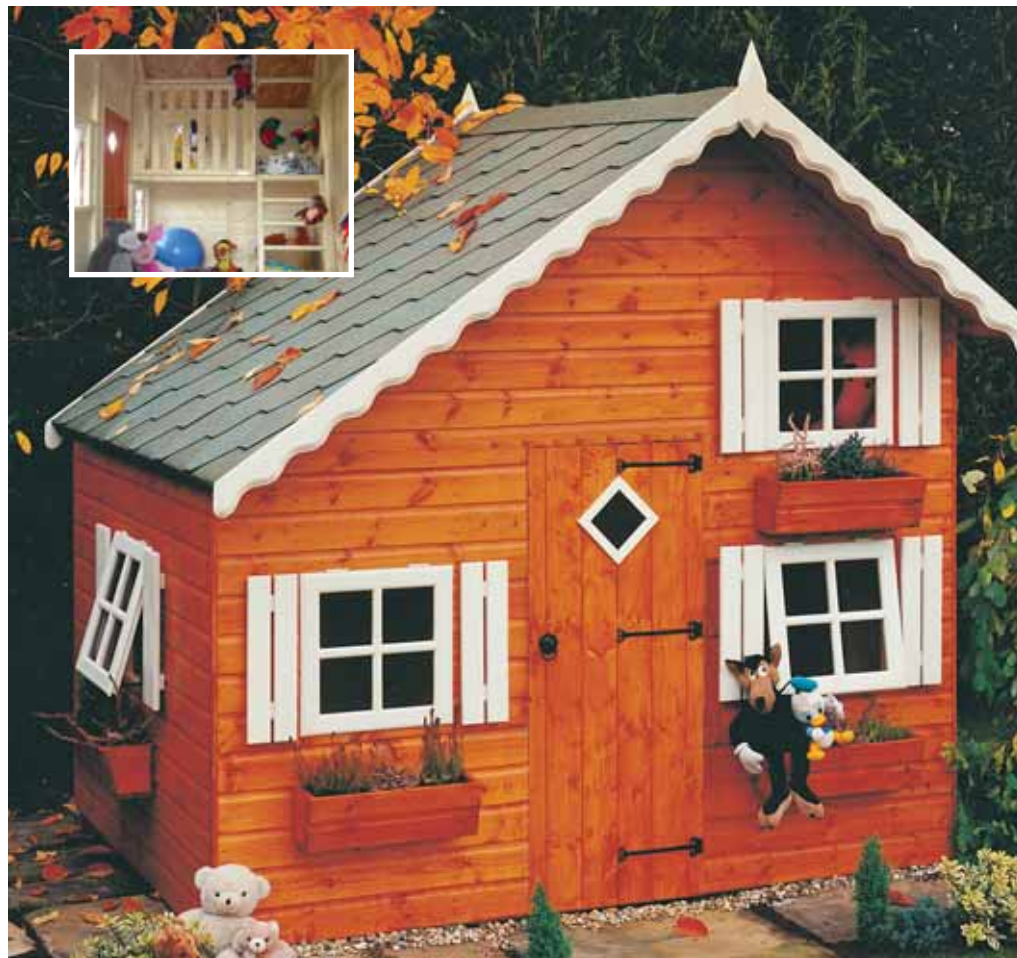

Hide

Pretty and petite. The fixed side window and shaped fascia to the front (there is no fascia provided for the back) add to the charm of this 'darling' building. The optional verandah as shown in the photograph has railings that are not shaped.

SIZE

1190 x 1190mm (4' x 4')

With optional 510mm (1'8") verandah,
1190 x 1700mm (4' x 5'8")

Internal eaves height: 1240mm (4'1")

Internal ridge height: 1460mm (4'9½")



Bunny

Cute and appealing. Roof trim and window box are optional extras.

SIZE

1190 x 1190mm (4' x 4')

Internal eaves height: 1160mm (3'9")

Internal ridge height: 1490mm (4'11")

Lodge

A playroom outside! A place for visiting playmates to sleep over?

The loft area is above the verandah therefore not impeding the internal height of the usable floor area.

The Lodge is for the larger garden it has been cleverly designed to maximise space whilst retaining a stunning appearance. All lower windows open.

SIZE

2390 x 2690mm (8' x 9') including verandah.

External eaves height: 1874mm (6'2½")

External ridge height: 2680mm (8'9")

The first dimension refers to the side with the door.



Crib

A playhouse for both son and daughter? 'Garage doors' in the side that are cleverly positioned under the bunk area allow for 'vehicles of destruction' to be safely garaged.

All lower windows open.

SIZE

2090 x 1790mm (7' x 6')

External eaves height: 1752mm (5'9")

1391mm (4'7")

External ridge height: 2340mm (7'8")

The first dimension refers to the side with the door.



Jailhouse

Every sheriff's dream house. Something for the indians to capture? Undoubtedly great fun! Fixed wooden 'bar' design windows and stable door with slatted verandah floor and 'horse' rail complete this appealing building. Supplied without nameplate.

SIZE

1790 x 1190mm (6' x 4')
plus 595mm (2') verandah.
Internal eaves height (back): 1579mm (5'2")
Internal ridge height: 1768mm (5'9")
The first dimension refers to the side with the door.

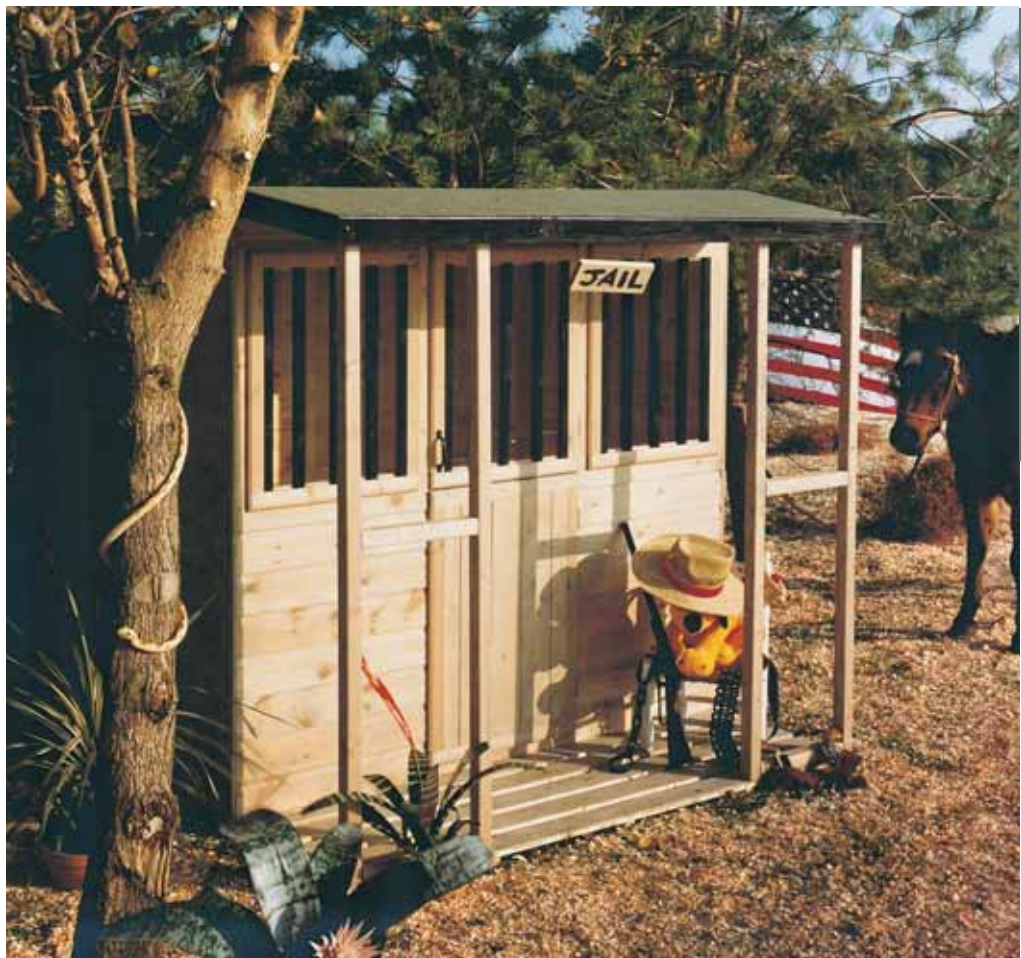

Den

Grandparents looking for a gift that will give lasting pleasure need look no further. Shaped window boxes and decorative shutters to both side windows, along with shaped fascia and verandah railings, add prestige to this delightful house. Front windows are fixed and both side windows open.

SIZE

1790 x 1190mm (6' x 4')
plus 595mm (2') canopy.
Internal eaves height: 1240mm (4'1")
Internal ridge height: 1570mm (5'2")
The first dimension refers to the side with the door.



Country Hutch

PAGE 27

Apex Dog Run

PAGE 28

Sanda Run

PAGE 28

Sark Kennels

PAGE 29

Pent Kennels

PAGE 29

Bird Table

PAGE 29

Bird House

PAGE 29

Aviary Coop

PAGE 29

Small Pet House

PAGE 29

Hutch and Drop run

PAGE 30

Mansion Hutch

PAGE 30

Poultry Coop

PAGE 30

Animal Ark

PAGE 30

Hen House

PAGE 30

Pet Run

PAGE 30



Pet Houses

Innovative Places

Do you have a 'friend' who requires special accommodation? All items shown in this range are made from solid Pine, unless otherwise stated, the cladding is Pine tongue and groove pattern and the framework is 35 x 35mm (1¼" x 1¼"). Some parts may be produced from Oriented Strand Board (OSB) which is a hard wearing wooden alternative to Pine. All pine timber parts are supplied pre-treated.

If you have any other item you may like produced from timber – please provide a photograph or drawing and we will be happy to quote.



SHIRE
BUILT AROUND OUR REPUTATION

Country Hutch

This large hutch is suitable for both rabbits and chickens. The large exercise area is complimented by a raised sleeping area.

The hutch offers both security and practical cleansing access points. A section of the front panel is removable to allow access for cleaning and removal of debris from the sleeping area.

SIZE

Total dimension: 1900 x 720mm
(6'3" x 2'4½")

Size of sleeping area: 720 x 720mm
(2'4½" x 2'4½")

Height of sleeping area: 1350mm (4'5")

Height of run: 930mm (3'½")

Apex Dog Run

Designed primarily for the larger dog the kennel comes with a choice of three run lengths. Two personnel doors allow easy access to all areas.

SIZE

Kennel size:

1980 x 1058mm (6'6" x 3'6")

Run size:

1980 x 990mm (6'6" x 3'3")

1980 x 1980mm (6'6" x 6'6")

1980 or 2970mm (6'6" x 9'9")

External eaves height: 1756mm (5'9")

External ridge height: 2090mm (6'10½")



Sanda Run

The roof and floor are produced from OSB. The run is produced without a floor. There are separate personal doors to kennel and run. Sliding door for dog use from kennel to run.

SIZE

1190 x 1190mm (4' x 4') kennel with 1790mm (6') long run.

1190 x 1190mm (4' x 4') kennel with 2390mm (8') long run.

External eaves height: 1487mm (4'10½")

External ridge height: 1687mm (5'6½")



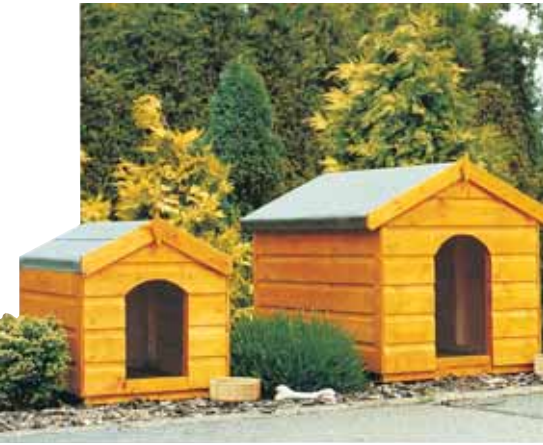

Sark Kennels

Give protection from the elements to enable your friend to be able to guard or sleep in comfort.

SIZE (wide x deep x high)

Small:
560 x 768 x 670mm (1'10" x 2'6" x 2'2½")
Opening: 260 x 375mm (10" x 1'3")
Large:
710 x 1150 x 870mm (2'4" x 3'9" x 2'10")
Opening: 260 x 480mm (10" x 1'7")



Pent Kennels

A private place to work, rest or play, or to just keep out of the way.

SIZE (wide x deep x high)

Small:
560 x 768 x 656mm (1'10" x 2'6" x 2'1½")
Opening 251 x 554mm (10" x 1'10")
Large:
712 x 1150 x 868mm (2'4" x 3'9" x 2'10")
Opening: 352 x 747mm (1'2" x 2'5½")



Bird Table

Give the birds a sanctuary from the dangers of the ground, with this well designed easy to assemble bird table. Resting 1500mm high with a generously sized sheltered table area it is sure to attract the high flyers in the area.

SIZE (wide x deep x high)

300 x 350 x 1500mm (11½" x 1'1¾" x 5')



Bird House

Lure the birds to into your garden with this attractive Bird House.

SIZE (wide x deep x high)

550 x 550 x 2800mm (1'9" x 1'9" x 9'2")



Aviary Coop

Large sleeping area and even larger area for flight.

SIZE (wide x deep x high)

918 x 2745 x 1830mm (3' x 9' x 6')



Small Pet House

Idyllic for any small pet. The Small Pet House offers a safe and secure enclosure for your smallest of friends. The house has a wired opening lid and a felted sheltered area.

SIZE (wide x deep x high)

Available in two sizes:
Small: 922 x 580 x 264mm (3' x 2' x 10½")
Large: 1530 x 760 x 264mm (5' x 2'6" x 10½")



Hutch and Drop Run

Ideal for all manner of family pets. Can be supplied with or without the drop run. If supplied without the run the hutch has small legs to raise it off the ground. If supplied with the drop run access is via a ramp which can be left open or closed.

SIZE (wide x deep x high)

Hutch: 1200 x 400 x 470mm
(3'11½" x 1'4" x 1'6½")

Run: 1180 x 890 x 540mm
(3'10½" x 2'11" x 1'4")

Hutch & Run Overall measurement:
1200 x 890 x 1010mm
(3"11" x 2'11" x 3'3")



Mansion Hutch

Every small pet's ideal aspirational home. Two sleeping sections and a living room. What pet could ask for more? 'Curtains' and 'chimney' complete the idyllic country residence. Drop run supplied as standard.

SIZE (wide x deep x high)

Overall measurement:
1520 x 1221 x 1124mm (5' x 4' x 3'8")

Hutch:
1520 x 395 x 666mm (5' x 1'3½" x 2'2")

Run:
1520 x 826 x 492mm (5' x 2'8½" x 1'7½")



Poultry Coop

Ideal for up to 6 chickens. Large run and coop with separate nesting box. A section of the back panel of the coop is removable to allow access for cleaning and removal of debris. There is ventilation to the top of the coop. The roof of the nesting box is hinged.

SIZE (wide x deep x high)

Overall measurement:
918 x 2745 x 1830mm (3' x 9' x 6')

Nesting box: 900mm deep.



Animal Ark

A very popular Run. This run provides freedom and exercise for your pet whilst keeping it safe. A sheltered area at one end should the weather change. With handles at both ends, the run is mobile and lightweight in design. Allowing easy storage and cleansing of the run.

SIZE (wide x deep x high)

Small: 635 x 1320 x 535mm (2'1" x 4'4" x 1'9")

Medium: 915 x 2134 x 790mm (3' x 7' x 2'7")

Large: 3150 x 1320 x 1070mm (10'4" x 4'4" x 3'6")



Hen House

Roosting box constructed from tongue & groove with OSB roof and floor. Contains roosting area and perch. No floor to run. Ideal for 2-3 chickens. Roof of roosting box is hinged to allow easy access.

SIZE (wide x deep x high)

Overall measurement:
1175 x 1526 x 598mm (3'10" x 5' x 1'11½")

Roosting Area:
1175 x 610 x 568mm (3'10" x 2' x 1'10")



Pet Run

Idyllic for any small pet. The Small Pet House offers a safe and secure enclosure for your smallest of friends. The house has sheltered area at one end and a wired opening lid.

SIZE (wide x high)

All are: 890 x 540mm (2'11" x 1'9")

Small: 1180mm (3'10½") long

Medium: 1520mm (5') long

Large: 1190mm (6') long

Wheelie Bin Store PAGE 31

View plastic or pine?

Storage Box PAGE 31

Many uses

Handy Store PAGE 32

For small or large garden

Jura Store PAGE 32

Superb durability

Bike Store PAGE 32

Free up the shed

Garden Stores PAGE 32

Ideal for small, unused space

Useful Store PAGE 33

Name says it all

Giant Store PAGE 33

Unbeatable for storage



SHIRE
BUILT AROUND OUR REPUTATION

Storage

Strong and Secure

Many homes need additional storage space because the garage is full, the summerhouse is full, the shed is full! We are pleased to offer in this section some attractive additional storage solutions. The units have been designed to give total access to the storage area offered.



Wheelie Bin Store

If you would prefer to see timber instead of plastic we have the ideal solution. Slatted solid timber construction, opening top can be hinged in 4 ways to give best lid access depending on location. Full width door for easy access.

SIZE

830 mm x 830mm
(2'8½" x 2'8½")
1200 mm high (3'11")



Storage Box

Wall constructed using solid pine tongue & groove. Could be used inside or outside. Ideal as blanket box, sports equipment store – the possibilities are almost endless. Hinged lid. Tongue & groove walls with OSB roof and floor.

SIZE

1250 mm x 550mm (4'1" x 1'9½")
645mm high (2'1")



Handy Store

As the name depicts it is a handy store for the small or large garden. It could be used as a dedicated space for garden tools.

SIZE

990 x 628 mm (3'3" x 1'1")
 External eaves height: 1766mm (5'9½")
 External ridge height: 1928mm (6'4")



Jura Store

No one ever has enough storage space, and sometimes space for storage can be tight too. This is the perfect solution. Supplied with OSB roof and floor.

SIZE

1790 x 890 mm (6' x 2'11")
 External eaves height: 1455mm (4'9")
 External ridge height: 1550mm (5'1")
 Door opening: 1315 x 1385mm (4'3¾" x 4'6½") (wide x high)



Bike Store

Can store 2 bikes comfortably. Or why not tidy away toys or garden equipment. Tongue & groove walls with OSB roof. No floor supplied. Full width double doors for easy access.

SIZE

1880 mm x 715 mm (6'2" x 2'4")
 Height at front: 1415mm (4'7¾")
 Height at rear: 1205mm (3'11½")



Garden Stores

Ideal to go into unused space to give neat and tidy storage solutions. Available in 2 sizes. Supplied with OSB roof and floor.

SIZE

Small: 630 x 590mm (2' x 2')
 Large: 1190 x 590mm (4' x 2')
 External eaves height: 1429mm (4'8")
 External ridge height: 1532mm (5')

Useful Store

Storage for all manner of equipment – garden, sports, barbeque, etc. Just a useful store. Supplied with OSB roof and floor.

SIZE

1228 x 1160mm (4' x 4')

External eaves height: 1628mm (5'4")

External ridge height: 1995mm (6'6½")



Giant Store

Unbeatable for storage as the double opening doors give complete access to an enormous area. Bikes, wheel-barrows, garden furniture – all can be accommodated in this building.

SIZE

1980 x 1058mm (6'6" x 3'6")

External ridge height: 2130mm (7')

External eaves height: 1860mm (6'1")

All deck kits:

Pressure Treated Deckboards 28 x 120mm on joists 28 x 120mm.

Posts: 90 x 90mm Spindles: 34 x 34mm Handrail: 35 x 80mm.

Overall height: 1190mm.

Comprehensive assembly instructions.



Type 1

Posts and spindles are supplied as standard, but it may suit your purpose better not to fit them?

SIZE

2200 x 2200mm (7'3" x 7'3")



Type 2

As can be seen from the photo an ideal shaped deck leading from your patio doors into the garden.

SIZE

2200 x 2800mm (7'3" x 9'2")



Type 3

This Deck can be placed adjacent to your property or equally used as a focal point in your garden for entertaining upon.

SIZE

4500 x 2200mm (14'9" x 7'3")



Type 4

The large shaped front section invites you onto the deck area. Although supplied with rails along the back section these could be omitted if placed adjacent to your house as a patio area leading into the garden.

SIZE

4500 x 3200mm (14'9" x 10'6")

Pine Lodges

A Place to Relax

A Shire Pine Lodge is an inspiration harnessing nature's finest to create an individual atmosphere to each building.

Shire enjoy unrivalled reputation for quality of product & service to customers.

Only selected high quality materials from proven sustainable sources have been used throughout the construction of our Pine Lodges.

Our imaginative designs are unique and inspirational to meet the aspirations of our customers.

Shire Pine Lodge Specials can be designed by our team to meet your specific requirements, home offices, leisure buildings, swimming pool enclosures, shops, cafeterias.

Our CAD operators are highly skilled and can work with you to design a building to meet with your requirement.



Assembly

Comprehensive accurate and easy to follow assembly instructions

are supplied with detail showing where each component fits. All log components are individually coded to correspond with the codes and detail shown on the assembly instructions. If you wish our distributors can offer you a complete package of advice, supply and assembly.



Some examples of our range are shown below, if you would like a brochure of the full range please call us on

01945 465295

or email

sales@shiregb.co.uk



Keilder

Picture shows 3590G x 5080

- Eaves height 2.1m Ridge height 2.7m (3590G) 2.8m (4190G)
- Timber Tongue & Groove roof & floor
- Pressure treated floor joists
- Side windows & door can be located in either side
- Heavy duty roofing felt (optional felt tiles)
- Optional 1.5m terrace
- No verandah option

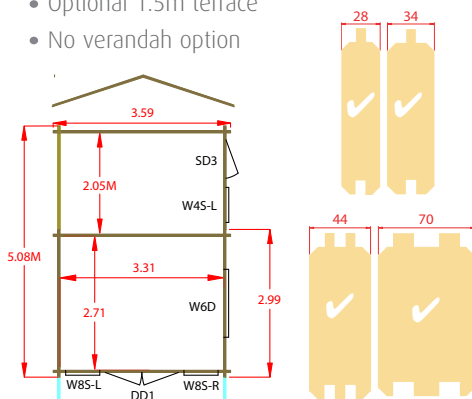

Hatfield

Picture shows 3590G x 4490

- Eaves height 2.1m Ridge height 2.7m (3580G) 2.8m (4190G)
- Timber Tongue & Groove roof & floor
- Pressure treated floor joists
- Window can be located in either side
- Heavy duty roofing felt (optional felt tiles)
- Verandah with pressure treated 25mm decking

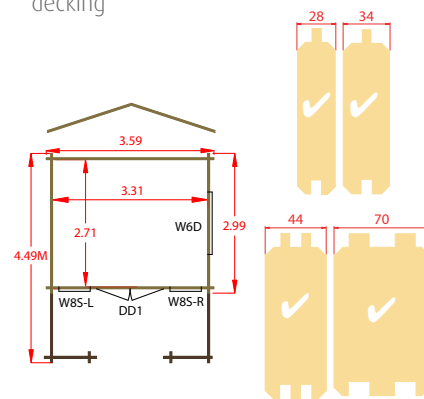

Bradenham

Picture shows 3800G x 5360

- Doors & windows can be located to either side
- Tongue & Groove roof
- Optional floor
- Pressure treated timber base plate
- Solid timber side hinged double doors
- Heavy duty roofing felt
- Eaves height 2.1m ridge height 2.7m

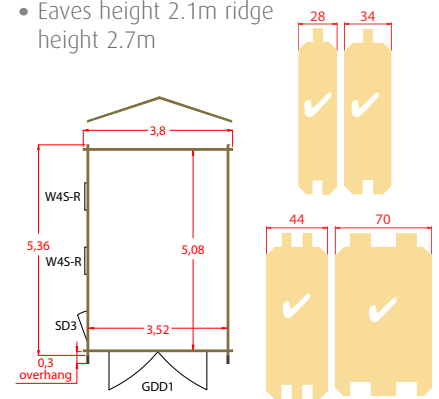



SHIRE

BUILT AROUND OUR REPUTATION

Brigstock Road, Wisbech,
Cambridgeshire PE13 3JJ

Tel: +44 (0) 1945 465295
Fax: +44 (0) 1945 582673
Email sales@shiregb.co.uk

www.shiregb.co.uk

